

# Mansfield®

# Swirl-way® Nuovo™ II



The unmatched Nuovo II with an adjustable back jet given you everything needed to fulfill your total bathing pleasure. This beautiful hour-glass shaped whirlpool in the larger six-foot size provides six jets perfectly placed for great hydromassage action. The Nuovo II, offers pleasing contemporary shape and built-in back support. Beautiful, yet functional, the Nuovo II is a perfect fit in any bathroom.

### Standard Features:

- 36" x 72" rectangle whirlpool
- SimpleTouch, two button control
- Five Magna-Swirl I Jets and One Micro directional jet provide a complete hydro-massaging action
  - One micro directional jet for a great back massage.
  - Magna-Swirl I jets are directionally and individually adjustable to massage the rest of your body.
- Powerful 2 HP pump creates an invigorating whirlpool action
- Cable operated drains in Color match, Chrome, Everbrass (PVD), or Brushed Nickel
- Dual air controls for the ultimate jet power control
- One contoured pillow in your choice of White, Bone or Biscuit
- Your choice of Color match, Chrome, Everbrass (PVD) and Brushed Nickel trim
- White, and Standard Colors

### Additional Options and Upgrades:

- **COMFORT PACKAGE:** In-line heater and MoodScape light
- **LUXURY PACKAGE:** SimpleSelect Control, four button control, 10 speed pump with massage mode, In-line heater and MoodScape light
- Premium and Designer Colors
- Removable apron
- Preinstalled nailing flange
- Antimicrobial acrylic in White, Bone or Biscuit

Order No.	Description	Approx. Wt.
5023	Rectangle Whirlpool 36" x 72" x 20" Specify color and options when ordering.	100 lbs.



# NUOVO II FEATURES AND PACKAGES



**SimpleTouch™ Control**  
Solid, state of the art, two function control with LCD display. Left button controls on/off, right button controls optional MoodScape light. Upgradeable to Luxury Package.



**Magna-Swirl™ | Jets**  
Powerful, individually adjustable jet is an exclusive Swirl-way design.



**Micro Directional Jet**  
One micro jet, adjustable in both direction and intensity, allows you to control your back hydromassage experience.

## Comfort Package

Consists of the MoodScape light and the solid state in-line heater. On/Off function of MoodScape is controlled by the SimpleTouch.



## Luxury Package

Upgrades the control to the SimpleSelect, solid state of the art, four function control with LCD display. Controls on/off, 10-speed pump, massage action and MoodScape light. Package also includes the solid state in-line heater and MoodScape light.



## ROUGH-IN DIMENSIONS

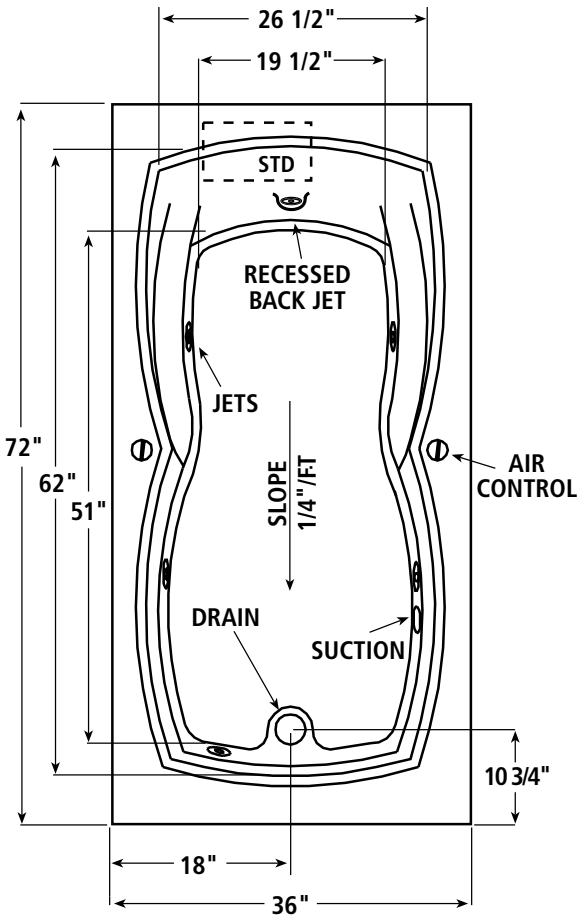

### OPTIONAL REMOVABLE APRON

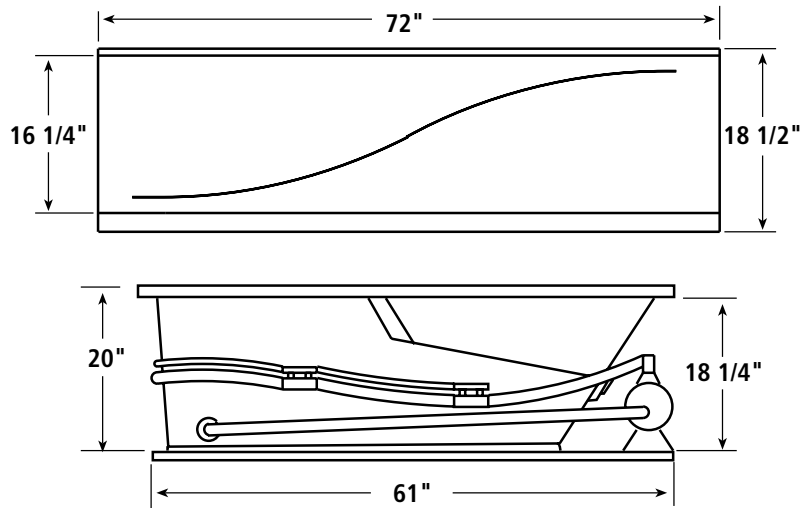

**Note:** Rough-in measurements may vary + - 1/4". If a factory installed nailing flange is added to a unit, add 1/8" to each side flanged.

- DIMENSIONS:** 36" x 72" x 20"
- MATERIAL:** Acrylic, fiberglass reinforced
- CONSTRUCTION:** Self-contained, pre-plumbed whirlpool bath with heat-bent rigid PVC Pipe, mounted on a pre-leveled thermoformed, drip pan base
- PUMP MOTOR:** 2 HP, Single speed, 120V, 60Hz
- ELECTRICAL REQUIREMENTS:** One, 120V, 20 AMP, GFCI outlet  
SimpleSelect upgrade requires two, 20 AMP, GFCI outlets
- NUMBER OF JETS:** 6
- AIR VOLUME CONTROLS:** Two
- WATER CAPACITY:** 58 gal. max., 38 gal. min.
- FLOOR LOADING:** 47 lbs./sq. ft.
- WEIGHT:** 100 lbs.
- SHIPPING WEIGHT:** 135 lbs.



Listed No. 2719



Listed No. SP-1179



Listed 47E6 hydromassage bathtub



Listed S.259 hydromassage bathtub



Various other state, city and local approvals.

When tested for compliance to the requirement of ANSI A112.19.7M and A112.19.8M for "Whirlpool Bath Appliances" and ANSI Z124.1 for "Plastic Bathtub Units" the tested units are found to comply and are acceptable for listing under the Terralab Engineers, Inc. follow-up service. Listed No. 15197.

\*certified for permanent electrical supply connection only.



Mansfield Plumbing Products LLC • Sales Services Toll Free 800-999-1459 • Fax 903-657-3450  
Website: [www.mansfieldplumbing.com](http://www.mansfieldplumbing.com) • Email: [custserv@mansfieldplumbing.com](mailto:custserv@mansfieldplumbing.com)